

5类线 (增强型)



用途

网络、通信关联设备用

特点

- 按照TIA/EIA 568B 2规格, 支持100MHz高速传输的LAN电缆
- 支持1000BASE-T(1Gbps)。
- 支持RoHS

构造示例

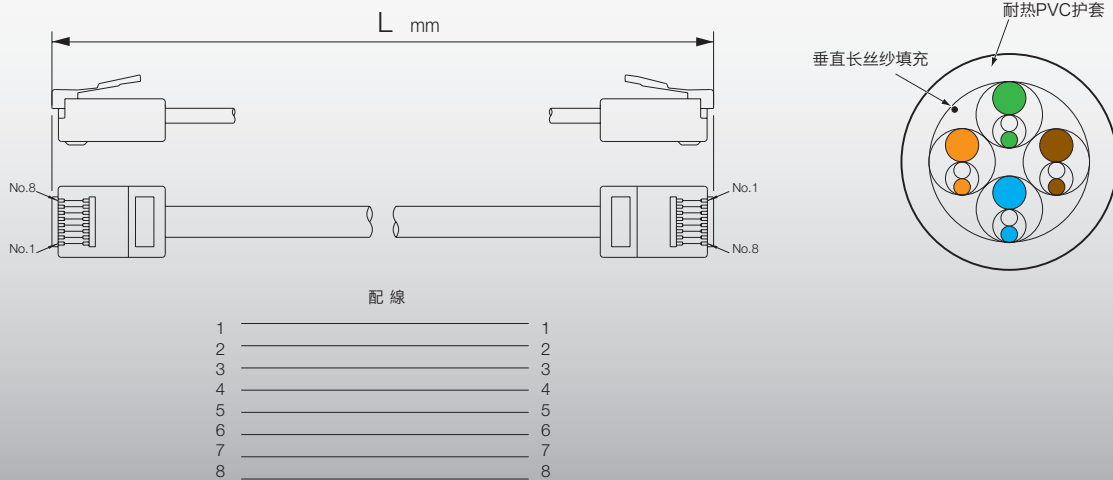

特性

频率 (MHz)	衰减量 dB/100m(Max.)	近端漏话衰减量 dB/100m(Min.)	功率总和近端漏话衰减量 dB/100m(Min.)	远端漏话衰减量 dB/100m(Min.)	功率总和远端漏话衰减量 dB/100m(Min.)	反射衰减量 dB/100m(Min.)
0.772	—	67.0	64.0	—	—	—
1	2.0	65.3	62.3	63.8	60.8	20.0
4	4.1	56.3	53.3	51.7	48.7	23.0
8	5.8	51.8	48.8	45.7	42.7	24.5
10	6.5	50.3	47.3	43.8	40.8	25.0
16	8.2	47.3	44.3	39.7	36.7	25.0
20	9.3	45.8	42.8	37.7	34.7	25.0
25	10.4	44.3	41.3	35.8	32.8	24.3
31.25	11.7	42.9	39.9	33.9	30.9	23.6
62.5	17.0	38.4	35.4	27.8	24.8	21.5
100	22.0	35.3	32.3	23.8	20.8	20.1